



FEATURES

- High reliability
- Flow rate 0.0005 ~2900 mL/min
- Compatibility various With Pump Drive
- Easy configuration tubing
- Accepts various tubing size
- Easily accessible stacked head

HOUSING

- Polyphenylene Sulfide (PPS)
- Good protection from corrosive liquids and vapors

Rotor

- 304 Stainless steel (SS) rotor and roller
- Good protection from corrosive liquids and vapors
- Number of rollers 3, 6

JenieLock SIMPLE PUMP HEAD

Rotor assembly



Three rollers
Standard using

Three rollers
Hi-pressure usin

Six rollers
Low pulse using



Stacking hardware

Pump head Mounting	Hardware No.
One	JPMH1
Two	JPMH3
Three	JPMH4
Four	JPMH4

High Accuracy

Low Price

JenieLock SIMPLE PUMP HEAD

SPECIFICATION

Description	JP-100	JP-101	JP-200	JP-300	JP-301
Flow capacity	0.0005 ~2300mL/min				
MAX RPM	600				
Rollers	3	6	3	3	6
Maximum torque	13 kg-cm				
Housing materials	Polyphenylene sulfide (PPS)				
Rotor materials	Stainless steel with PPS				
Operating Temp	0 ~ 40°C				

Ordering Information

Model No.	Description
JP-100	Standard 1- channel 3-Rollers Simple Pump head
JP-101	Low Pulse 1- channel 6-Rollers Simple Pump head
JP-200	Hi-Flow rate 1-channel 3-Rollers Simple Pump head
JP-300	Standard 2- channel 3-Rollers Simple Pump head
JP-301	Low Pulse 2- channel 6-Rollers Simple Pump head

Dimension cm(inch)

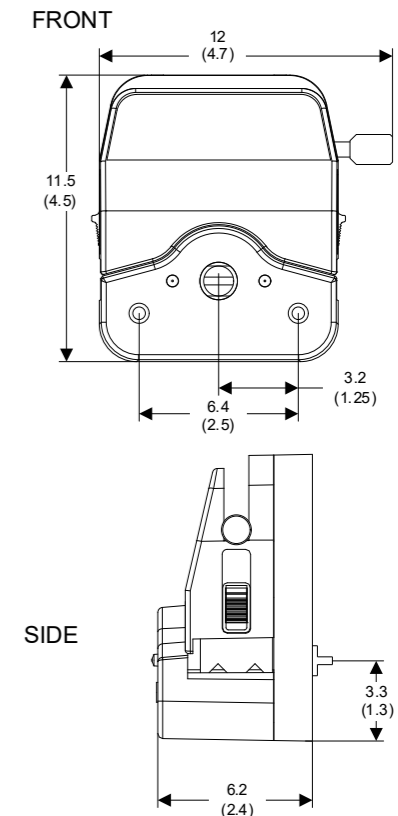

TUBING & PUMPHEAD SELECT INFORMATION

Model No.	Number of rollers	Drive rpm	Tubing Size Inside diameter (Inch / No.)					
			1/32" (#13)	1/16" (#14)	1/8" (#16)	3/16" (#25)	1/4" (#17)	5/16" (#18)
Standard Pump head								
JP-100	3	0.01 ~ 600	0.0005 ~ 36	0.002 ~ 130	0.008 ~ 480	0.0165 ~ 1000	0.0285 ~ 1700	0.038 ~ 2300
		10 ~ 600	0.6 ~ 36	2.1 ~ 130	8 ~ 480	17 ~ 1000	28 ~ 1700	38 ~ 2300
		1.6 ~ 100	0.1 ~ 6	0.4 ~ 21	1.4 ~ 80	3 ~ 170	5 ~ 280	6 ~ 380
JP-101	6	0.01 ~ 600	0.0004 ~ 23	0.002 ~ 84	0.005 ~ 310	0.013 ~ 770	-	-
		10 ~ 600	0.4 ~ 23	1.4 ~ 84	5.2 ~ 310	12.9 ~ 770	-	-
		1.6 ~ 100	0.065 ~ 3.9	0.23 ~ 13.6	0.83 ~ 51	2.1 ~ 128	-	-
Two-Channel Pump head								
JP-300	3	0.01 ~ 600	0.0005 ~ 36	0.002 ~ 130	0.008 ~ 480	0.0165 ~ 1000	0.0285 ~ 1700	0.038 ~ 2300
		10 ~ 600	0.6 ~ 36	2.1 ~ 130	8 ~ 480	17 ~ 1000	28 ~ 1700	38 ~ 2300
		1.6 ~ 100	0.1 ~ 6	0.4 ~ 21	1.4 ~ 80	3 ~ 170	5 ~ 280	6 ~ 380
JP-301	6	0.01 ~ 600	0.0004 ~ 23	0.002 ~ 84	0.005 ~ 310	0.013 ~ 770	-	-
		10 ~ 600	0.4 ~ 23	1.4 ~ 84	5.2 ~ 310	12.9 ~ 770	-	-
		1.6 ~ 100	0.065 ~ 3.9	0.23 ~ 13.6	0.83 ~ 51	2.1 ~ 128	-	-
Hi-performance Pump head								
JP-200	3	0.01 ~ 600	0.0165 ~ 1000	0.0285 ~ 1700	0.038 ~ 2300	0.048 ~ 2900	-	-
		10 ~ 600	17 ~ 1000	28 ~ 1700	38 ~ 2300	48 ~ 2900	-	-
		1.6 ~ 100	3 ~ 170	5 ~ 280	6 ~ 380	8 ~ 480	-	-